

F

L

FLAM

A

M



mondel  
MEAT THE FISH

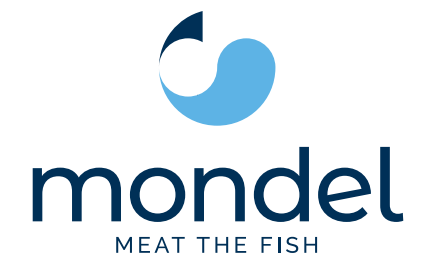



# FLAM

Spazio ridotto, infinite possibilità. La vetrina refrigerata Flam è il tocco finale che completa il tuo punto vendita: design essenziale e di tendenza, perfetto per esporre specialità pronte da gustare.

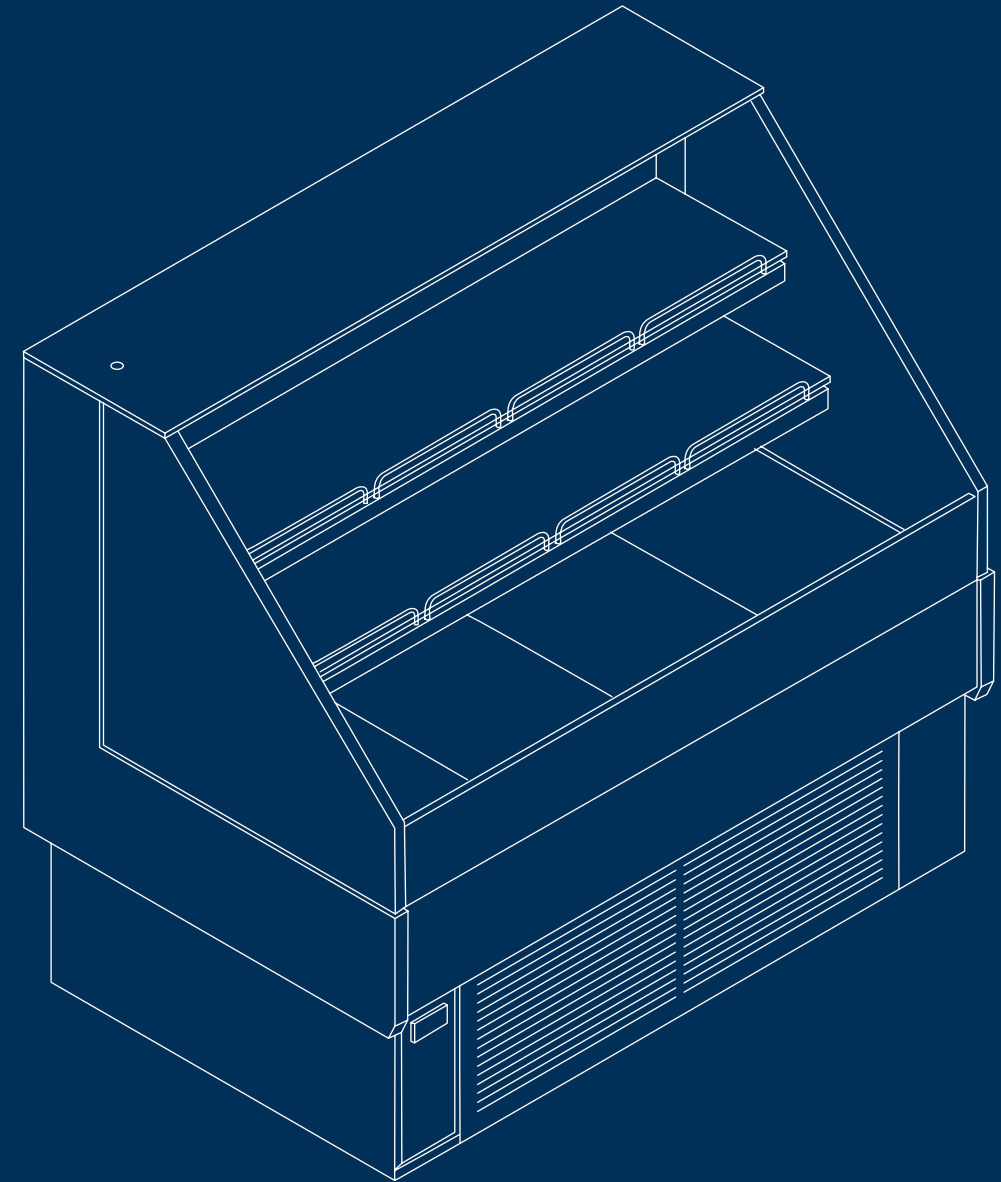

Reduced space, countless options. The FLAM refrigerated display counter is the finishing touch to complete your retail store: essential, trendy design, ideal for displaying specialities ready to enjoy.

Espace réduit, possibilités infinies. La vitrine réfrigérée FLAM est la touche finale qui complète votre point de vente : un design sobre et tendance, parfait pour présenter des spécialités prêtes à consommer.

Wenig Platz, unendlich viele Möglichkeiten. Die Kühlvitrine FLAM ist das i-Tüpfelchen in Ihrer Verkaufsstelle: schlichtes, trendiges Design, perfekt für die Auslage Ihrer servierfertigen Spezialitäten.

Spalle panoramiche in vetrocamera e illuminazione di serie LED 4000°K su tutti i ripiani in vetro, per dare massima visibilità ai prodotti esposti.

Panoramic double-glazed side panels and standard LED 4000°K lighting on all glass shelves provide maximum visibility for the products on display.

Les montants panoramiques à double vitrage et l'éclairage LED 4000°K de série sur toutes les tablettes en verre offrent une visibilité maximale des produits exposés.

Panorama-Isolierverglasung und serienmäßige LED-Beleuchtung (4000 °K) auf allen Glasböden für eine optimale Sicht auf die ausgestellte Ware.



Il banco Mondel pensato specificatamente per il Take Away, con interno ed esterno verniciato RAL 9005, per far risaltare le tue squisitezze pronte da gustare: sushi, piatti freddi e altre specialità per ogni occasione, dagli happy hour ai pranzi veloci.

The Mondel display counter, specifically designed for a Take-Away service, has a RAL 9005 painted interior and exterior to highlight your ready-to-enjoy delicacies: sushi, cold dishes and other specialities for all occasions, from happy hours to quick lunches.



FRESH  
COLD  
DISHES



TASTY  
FISH &  
SUSHI

# FRESHNESS TO EAT IN OR TAKE AWAY





# Features

**Semiverticale**  
**Semi-vertical**  
**Semi-vertical**  
**Halbvertikal**

 Ventilato  
Ventilated  
Ventilé  
Belüftet

 Con due ripiani refrigerati  
With two refrigerated  
shelves  
Avec deux tablettes  
réfrigérées  
Mit zwei Kühlfächern

 LED 4000°K su cappello  
4000°K LED top lighting  
Eclairage LED 4000°K sur la  
cloche  
LED-Beleuchtung auf der  
Haube

 Quadro elettronico  
Electronic panel  
Tableaub électrique  
Elektronische Schalttafel





## How to stand out.

Crea un'area promozionale d'impatto, per bevande e food-to-go. Flam è disponibile in diverse lunghezze e si adatta al layout del tuo punto vendita.

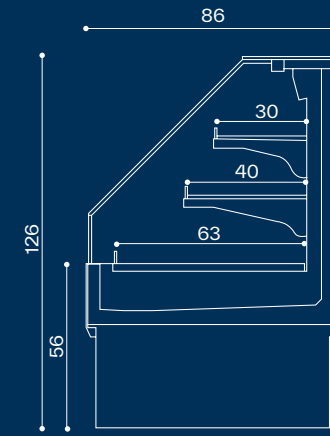

### How to stand out.

Create a striking promotional area for drinks and food-to-go. Flam is available in various lengths and adapts to the layout of your retail store.

### Comment se distinguer.

Créez un espace promotionnel impactant pour les boissons et les aliments à emporter. Flam est disponible en différentes longueurs et s'adapte à l'agencement de votre point de vente.

### Die Vitrine als Hingucker.

Sie bietet eine wirkungsvolle Werbefläche für Getränke und Essen zum Mitnehmen. Flam ist in verschiedenen Längen erhältlich, passend zum Layout Ihres Ladens.

The island  
of Freshness

